

What is Daylighting?

Daylighting is the practice of placing windows or other openings and reflective surfaces so that during the day, natural light provides effective interior lighting. Particular attention is given to daylighting when the aim is to maximize visual comfort or to reduce energy use. A daylit zone is the floor area under skylights or next to windows. Types of daylit zones include **Primary Sidelit**, **Secondary Sidelit**, and **Skylit**.

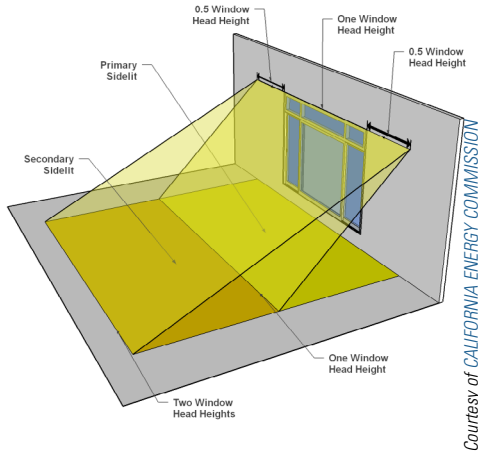

The **primary sidelit daylit zone** is an area on a plan directly adjacent to each vertical glazing, one window head height deep into the area, and window width plus 0.5 times window head height wide on each side of the rough opening of the window.

The **secondary sidelit daylit zone** is the area on a plan directly adjacent to each vertical glazing, two window head heights deep into the area, and window width plus 0.5 times window head height wide on each side of the rough opening of the window.

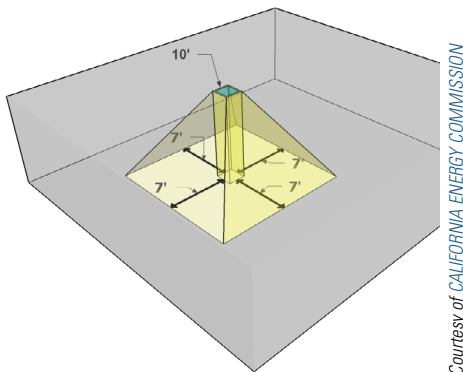

The **skylit daylit zone** is an area of the space equal to the area of the skylight plus a distance 0.7 times the average height of the skylight above the floor, extending out from the edges of the skylight

Why?

Energy savings can be achieved from the reduced use of artificial lighting, either by simply installing fewer electric lights because daylight is present, or by installing controls to dim/switch electric lights automatically in response to the presence of daylight.

Relevant Code Sections

2019 California Building Energy Efficiency Standards, Title 24, Part 6:

- [Section 100.1](#) – Definitions: Sidelit Daylit Zone (Primary and Secondary), Skylit Daylit Zone
- [Section 110.9\(b\)2](#) – Daylighting Controls
- [Section 130.1\(d\)](#) – Automatic Daylighting Controls
- [Section 140.3\(a\)6](#) – Skylight Requirements
- [Section 140.3\(c\)](#) – Minimum Daylighting Requirement for Large Enclosed Spaces
- [Section 140.3\(d\)](#) – Daylighting Design Power Adjustment Factors (PAFs)
- [Section 140.6\(a\)2](#) – Reduction of Wattage through Controls
- [Section 140.6\(d\)](#) – Secondary Daylit Zone Control Requirements
- [Section 141.0\(b\)2i](#) – Alterations Requirements
- [Nonresidential Compliance Manual Chapter 3.3](#) – Fenestration (Window/Skylight/ Glazed Door)
- [Nonresidential Compliance Manual Chapter 5.4.4](#) – Automatic Daylighting Controls
- [Nonresidential Compliance Manual Chapter 5.5](#) – Other Prescriptive Daylighting Requirements - Daylighting, Daylighting Devices, and Secondary Sidelit Daylit Zones

Relevant Compliance Forms

- [NRCC-ENV-E](#): Envelope Component Approach
- [NRCC-LTI-E](#): Indoor Lighting
- [NRCI-LTI-01-E](#): Indoor Lighting
- [NRCI-LTI-02-E](#): EMCS or Lighting Control System - Installation Certificate
- [NRCA-LTI-03-A](#): Automatic Daylighting Controls - Acceptance Test

Control Requirements & Daylit Zones

The 2019 Title 24, Part 6 Building Energy Efficiency Standards (Energy Code) contain daylighting control requirements that apply to many spaces. Mandatory daylighting controls are required for enclosed spaces with at least 120 watts of general lighting power in the combined **primary sidelit** and **skylit daylit zones**, and where the fenestration area is 24 ft² or greater. **Daylit zones** must be shown on plans, and combined illuminance cannot be less than the designed illuminance. Exceptions to the Mandatory daylighting requirements apply for skylights that are shaded by external objects for more than 1500 daytime hours per year, and for **primary sidelit daylit zones** adjacent to vertical windows that have fixed overhangs with a broad projection, preventing natural daylight. Luminaires in **sidelit daylit zones** for retail merchandise sales or wholesale showrooms are also exempt from daylighting controls. When using the Prescriptive compliance method, luminaires in the **secondary sidelit zone** must also have daylighting controls.

When photosensors are located within the **daylit zone**, locate at least one so that it is not readily accessible to unauthorized personnel. Additionally, the location where calibration adjustments are made to the automatic daylighting controls must be readily accessible to authorized personnel, but may be inside a locked case or under a cover which requires a tool for access. Areas with daylight dimming plus off controls on luminaires in a **skylit daylit zone** or primary sidelit daylit zone qualify for a Power Adjust Factor (PAF) of 0.10

For spaces required to install multilevel controls under [Section 130.1\(b\)](#), adjust lighting via continuous dimming or the number of control steps provided by the multilevel controls. For example, linear fluorescent lamps greater than 13 Watts require either continuous dimming, stepped dimming down to a range of 20-40% on the lowest step, or switching lamps with a minimum of four lamps per luminaire. Note that Acceptance Testing is required for lighting controls. Requirements and procedures can be found in [Section 130.4](#).

Dimming Performance

Installed daylighting controls must operate so that when the daylight illuminance exceeds 150% of the design illuminance for electric lighting, the general lighting power is reduced by a minimum of 65%. For example, if the designed illuminance in the space is 40 footcandles (fc), when the daylight illuminance reaches 60 fc, the controls must reduce lighting power by at least 65%. When possible, controls that can automatically maintain illuminance levels at the designed illuminance at all times of the day are an even better solution.

Daylighting Power Adjustment Factor Credits

The 2019 Energy Code offers compliance credits for several advanced daylighting design features (see [Sections 140.3\(d\)](#) and [140.6\(a\)2](#)). These include daylight dimming plus off controls, clerestory windows, interior or exterior horizontal slats, and interior or exterior light shelves. The compliance credits are calculated by multiplying the watts of installed lighting in the affected area times a PAF for the measure from [Table 140.6-A](#). Installing clerestory fenestration or horizontal slats allows a 5% PAF, while daylight dimming plus off controls, or light shelves allow a 10% PAF.

The calculated wattage credit is subtracted from the actual installed lighting power on the compliance forms to help comply with the Energy Code. See [Table 140.6-A](#) for information on which daylighting controls can be combined for additional compliance credit.



Parking Garages

Mandatory daylighting control requirements for parking garages are different than for other spaces. For instance, parking garage daylight controls are mandatory for secondary sidelit zones, whereas this is not the case for interior areas of the building.

Parking garages that have a combined glazing or opening area of 36 square feet or greater must also comply with the daylighting control requirements of the Energy Code, except when the combined general lighting power in the sidelit daylit zones is less than 60 watts. Daylighting controls are not required in parking garage daylight adaption zones, which is a vehicular path intended to provide a transition between exterior and interior illumination levels and does not include parking areas.

Primary and secondary daylit zones can be controlled together. Daylighting controls for parking garages can be on/off, where other spaces require continuous or stepped dimming controls. Lighting in the primary and secondary daylit zones of parking garages must be completely turned off when daylight illuminance exceeds 150% of the designed illuminance.

Daylighting Requirements for Large Enclosed Spaces

Requirements set forth in [Section 140.3\(c\)](#) establish large enclosed spaces with high ceilings must have a minimum amount of daylight available when using the Prescriptive compliance method. The requirements apply for buildings in climate zones 2 through 15 with a space that has:

1. Floor area greater than 5,000 ft² directly under a roof **and**
2. Ceiling height greater than 15 ft **and**
3. Have a general lighting system with a lighting power density equal to or greater than 0.5 W/ft²

Buildings that meet all of the above criteria must have at least 75% of the floor area within skylit or primary sidelit daylight zones.

Per [Section 140.3\(a\)6](#), the skylight area cannot comprise more than 5% of the gross roof area. However, if it is an atrium over 55 feet in height, the skylight area may make up 10% of the gross exterior roof area. For large enclosed spaces meeting the criteria above, the skylight area must be at least 3% of the total floor area in the space within a horizontal distance of 0.7 times the average ceiling height from the edge of rough opening of skylights, or the product of the skylight area and visible transmittance (VT) must be at least 1.5% of the total floor area in the space within a horizontal distance of 0.7 times the average ceiling height from the edge of rough opening of skylights. In other words, the skylight area must be at least 3% of the skylit daylight zone area or the skylight area times the VT must be at least 1.5% of the skylit daylight zone area. To accomplish this requires careful sizing and placement of skylights. Typically a number of smaller skylights, spaced so that the daylight areas from each do not overlap, is recommended to meet Prescriptive requirements. See the [Nonresidential Compliance Manual Chapter 5.5.22](#) for more detailed guidance.

For most spaces, a skylight area that is 3% to 4% of the gross roof area can provide necessary daylight area coverage, while limiting solar heat gain.

Forms: Which and When

During Design:

- [NRCC-ENV-E](#): Envelope Component Approach
- [NRCC-LTI-E](#): Indoor Lighting

Why?: To show compliance with the Energy Code for minimum daylighting requirements for large enclosed spaces and for both Mandatory daylighting controls and advanced daylighting design features for compliance credit.

During Construction:

- [NRCI-LTI-01-E](#): Indoor Lighting - Installation Certificate
 - Completed by the installing contractor and available for Inspector when onsite.
- [NRCI-LTI-02-E](#): EMCS or Lighting Control System - Installation Certificate
 - Completed by the installing contractor and available for the Inspector when onsite
- [NRCI-LTI-05-E](#): Power Adjustment Factors
 - (Optional) Completed if design claims compliance credit for dimming plus off daylighting controls or other advanced daylighting features
- [NRCA-LTI-03-A](#): Automatic Daylighting Control - Acceptance Test

Why?: To verify the field installation meets or exceeds code

For More Information

Primary Documents

- Energy Code Section 130.1(d) - Automatic Daylighting Controls
energycodeace.com/site/custom/public/reference-ace-2019/Documents/section1301mandatoryindoorlightingcontrols.htm
- Energy Code Section 140.3(a)6 - Skylight Requirements
energycodeace.com/site/custom/public/reference-ace-2019/Documents/section1403prescriptiverequirementsforbuildingenvelopes.htm
- Energy Code Section 140.3(c) - Minimum Daylighting Requirement for Large Enclosed Spaces
energycodeace.com/site/custom/public/reference-ace-2019/Documents/section1403prescriptiverequirementsforbuildingenvelopes.htm
- Energy Code Section 140.3(d) - Daylighting Design Power Adjustment Factors (PAFs)
energycodeace.com/site/custom/public/reference-ace-2019/Documents/section1403prescriptiverequirementsforbuildingenvelopes.htm
- Energy Code Section 140.6(a)2 – Reduction of Wattage through Controls
energycodeace.com/site/custom/public/reference-ace-2019/Documents/section1406prescriptiverequirementsforindoorlighting.htm
- Energy Code Section 140.6(d) - Secondary Daylit Zone Control Requirements
energycodeace.com/site/custom/public/reference-ace-2019/Documents/section1406prescriptiverequirementsforindoorlighting.htm
- Energy Code Section 141.0(b)2I - Alterations Requirements
energycodeace.com/site/custom/public/reference-ace-2019/Documents/section1410additionalterationsandrepairsstoexistingnonresidential1.htm
- Energy Code Nonresidential Compliance Manual Chapter 3.3 – Fenestration (Window/Skylight/Glazed Door)
energycodeace.com/site/custom/public/reference-ace-2019/Documents/33fenestrationwindowskylightglazeddoor.htm
- Energy Code Nonresidential Compliance Manual Chapter 5.4.4 – Automatic Daylighting Controls
energycodeace.com/site/custom/public/reference-ace-2019/Documents/54mandatorylightingcontrols.htm

- Energy Code Nonresidential Compliance Manual Chapter 5.5– Other Prescriptive Daylighting Requirements – Daylighting, Daylighting Devices, and Secondary Sidelit Daylit Zones
energycodeace.com/site/custom/public/reference-ace-2019/Documents/55otherprescriptivedaylightingrequirementsdaylightingdaylighting.htm

Compliance Forms

- Nonresidential Compliance Forms
energycodeace.com/NonresidentialForms/2019

California Energy Commission Information & Services

- Energy Code Hotline: 1-800-772-3300 (Free) or Title24@energy.ca.gov
- Online Resource Center
energy.ca.gov/programs-and-topics/programs/building-energy-efficiency-standards/online-resource-center
 - The Energy Commission’s main web portal for Energy Code, including information, documents, and historical information

Additional Resources

- California Lighting Technology Center (CLTC) Guides:
 - Nonresidential Lighting: What’s New in the 2019 Title 24, Part 6 Code?
cltc.ucdavis.edu/publication/nonresidential-lighting-whats-new-2019-title-24-part-6-energy-code
- Energy Code Ace:
EnergyCodeAce.com
 - An online “one-stop-shop” providing free resources and training to help appliance and building industry professionals decode and comply with Title 24, Part 6 and Title 20. The site is administered by California’s investor-owned utilities.
Of special interest: Fact Sheets
EnergyCodeAce.com/content/resources-fact-sheets/
 - Nonresidential Lighting Mandatory Controls 2019Please register with the site and select an industry role for your profile in order to receive messages about all our free offerings!



This program is funded by California utility customers and administered by Pacific Gas and Electric Company (PG&E), San Diego Gas & Electric Company (SDG&E®), Southern California Edison Company (SCE), and Southern California Gas Company (SoCalGas®) under the auspices of the California Public Utilities Commission.

© 2019 PG&E, SDG&E, SoCalGas and SCE. All rights reserved, except that this document may be used, copied, and distributed without modification. Neither PG&E, SoCalGas, SDG&E, nor SCE — nor any of their employees makes any warranty, express or implied; or assumes any legal liability or responsibility for the accuracy, completeness or usefulness of any data, information, method, product, policy or process disclosed in this document; or represents that its use will not infringe any privately-owned rights including, but not limited to patents, trademarks or copyrights. Images used in this document are intended for illustrative purposes only. Any reference or appearance herein to any specific commercial products, processes or services by trade name, trademark, manufacturer or otherwise does not constitute or imply its endorsement, recommendation or favoring.